

Combining Dual Frequency Doppler (DFD) technology with digital signal processing, the Polysonics SX30 features exceptional performance and simple operation. Designed for the measurement of fluids which contain particulate, the Polysonics SX30 is immune to much higher levels of external noise allowing it to operate in a broader range of applications than with standard Doppler technology.

Polysonics SX30

Portable Dual Frequency Doppler Flowmeter for the Water and Wastewater, Power and Chemical Industries



Polysonics SX30 transducers feature stainless steel suitable for most pipe materials.



Applications

- Slurries
- Primary Sludge
- Dredging
- Activated Sludge

The Dual Frequency Doppler (DFD) technology significantly improves the ability of the Polysonics SX30 to operate in what were previously considered marginal applications for Doppler flowmeters.

Unlike conventional Doppler flowmeters, which operate at a single frequency, the Polysonics SX30 generates two independent ultrasonic signals at different frequencies. By correlating these frequencies, the instrument identifies and eliminates noise errors from sources such as variable frequency drives.

The operation of the Polysonics SX30 is enhanced by an Expert System which allows the flowmeter to automatically "learn" the application parameters. As a result, the Polysonics SX30 can be set up in four easy

steps and at a fraction of the time necessary to configure competitive flowmeters.

The design features a sealed membrane keypad making the unit fully weatherproof. Large keys make it easy to enter data and navigate the on-screen menu—even with gloved hands.

Features and Benefits

- Accuracy to $\pm 1\%$
- Simple and easy to use
- Excellent noise immunity
- NEMA 6 environmental sealing
- Up to 24 hours battery operation
- Powerful 90,000 point data logger
- Serial interface port for data retrieval via HydraScan software
- Universal AC adapter charging socket

Polysonics SX30 Portable Dual Frequency Doppler Flowmeter

Specification	
Performance Specifications	
Velocity Range	0.06 to 5.5 m/s (0.2 to 18 ft/s); volumetric value based on cross-sectional area of pipe
Accuracy	±1% of velocity full scale
Fluids	Liquids containing particulate entrained gas bubbles
Pipe Size	12 to 5000 mm (0.5 to 200 in)
Physical Specifications	
Transmitter	NEMA 6 (IP67), waterproof against accidental immersion and splashproof with lid open
Transducers	Encapsulated dual frequency sensor heads, encased in stainless steel shrouds with integral transducer clamps and BNC connectors 5 m (16 ft) cable - standard
Weight	Approximately 4.9 kg (11 lbs) - 12 hour battery Approximately 6.8 kg (15 lbs) - 24 hour battery
Functional Specifications	
Outputs	4-20 mA (into 750 ohms); 12-bit, 5 kV, opto-isolated; loop or self-powered RS232 serial interface
Power Supply	Built in lead acid gel battery 12 hours continuous operation — standard 24 hours continuous operation — option 90-264 Vac, 50/60 Hz 12-15 Vdc auxiliary power port
Charge Period	8 hours
Keypad	21 key with tactile action
Display	Backlit, 240 x 60 dot, high resolution graphics display
Data Logger	90,000 point data logger Programmable in log intervals of 30 sec, 1, 5, 15, 30, 60 mins <i>HydraScan</i> retrieval software for Windows® included as standard Compatible with Microsoft® Excel, Lotus® 1-2-3 and other similar packages
Temperature Range	Transducers: -40° to +122°C (-40° to +250°F); Coax cable: limited up to +80°C (+176°F) Electronics: +5° to +40°C (+41° to +104°F), CSA approved; -20° to +60°C (-4° to +140°F), non-CSA approved
Compliance	Designed to meet CE and NRTL/C (CSA) for non-hazardous areas

Figure 1 – Polysonics SX30 Dimensional Diagram

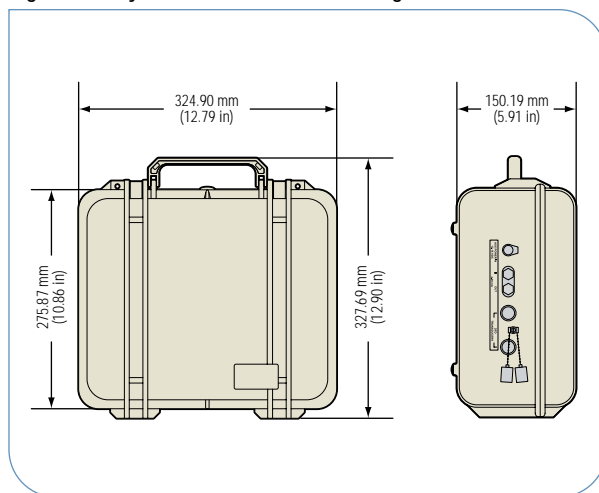

Ordering Information

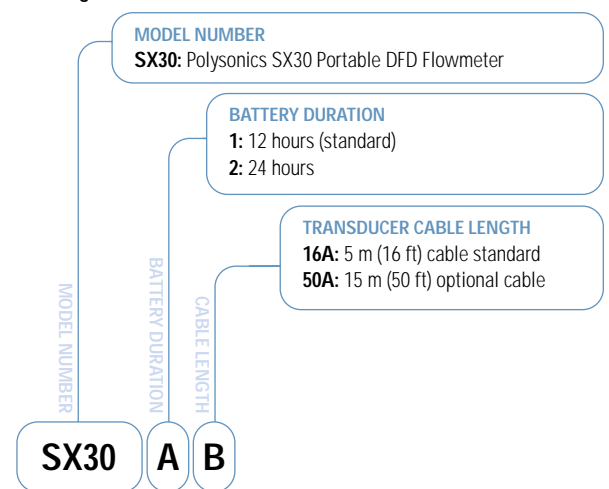

©2003 Thermo Electron Corporation. All rights reserved. Thermo Electron Corporation and Analyze, Detect, Measure, Control are trademarks of Thermo Electron Corporation. Lotus is a trademark of International Business Machines Corporation in the United States, other countries or both. Microsoft and Windows are registered trademarks of Microsoft Corporation in the United States and/or other countries. Literature Code PI.2011.0618

United Kingdom: King's Worthy, Winchester Hampshire S023 7QA UK +44 (0)1962 625000 +44 (0)1962 88530 fax

Process Instruments United States: 9303 W. Sam Houston Pkwy. S. Houston, TX 77099 USA (713) 272-0404 (713) 272-2273 fax

www.thermo.com/process